

6. REMOVE TRANSMISSION WIRE

- (a) Disconnect the transmission wire connector.
- (b) Remove the bolt and pull out the transmission wire.

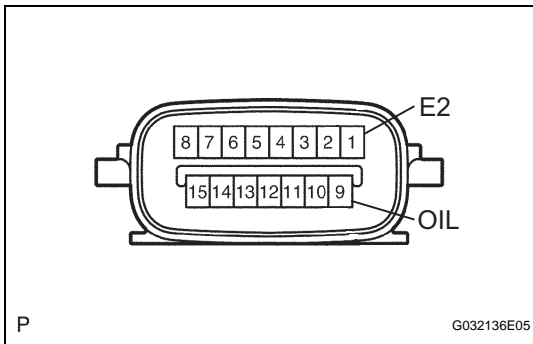

INSPECTION

1. INSPECT TRANSMISSION WIRE

- (a) Using an ohmmeter, measure the resistance between the terminals.

Standard resistance

Tester Connection	Specified Condition
1 (E2) - 9 (OIL)	3 to 4 kΩ at 20 °C (68°F)
1 (E2) - 9 (OIL)	0.22 to 0.28 kΩ at 110°C (230°F)

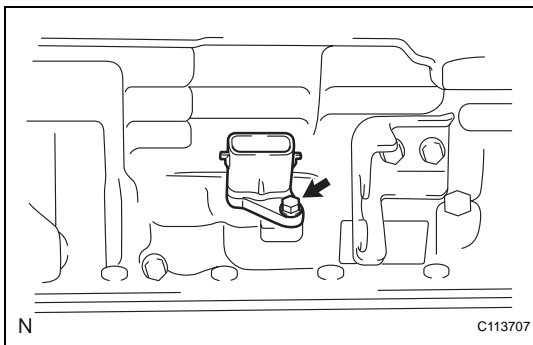

INSTALLATION

1. INSTALL TRANSMISSION WIRE

- (a) Install the transmission wire with the bolt.
Torque: 5.4 N*m (55 kgf*cm, 48 in.*lbf)
- (b) Connect the transmission wire connector.

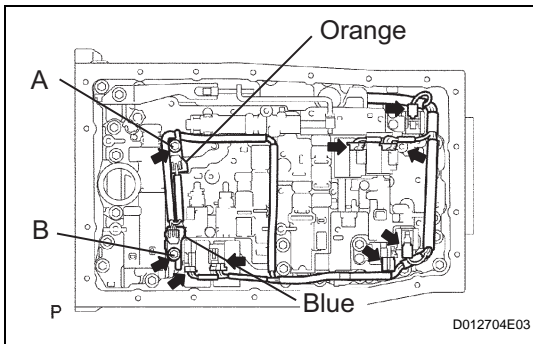

2. CONNECT TRANSMISSION WIRE

- (a) Connect the 7 connectors to the solenoid valves.
- (b) Install the 2 clamps with the 2 bolts.
Torque: 10 N*m (100 kgf*cm, 7 ft.*lbf) for bolt A
11 N*m (112 kgf*cm, 8 ft.*lbf) for bolt B
Bolt length:
12 mm (0.47 in.) for bolt A
36 mm (1.42 in.) for bolt B
- (c) Connect the ATF temperature sensor.

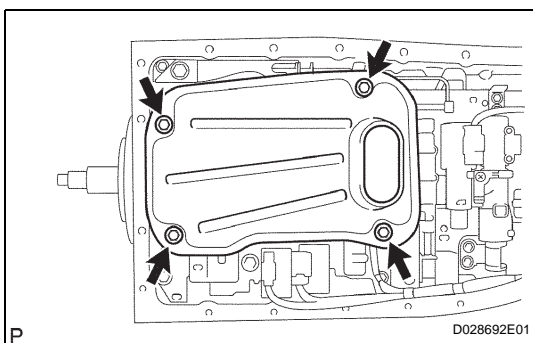

3. INSTALL VALVE BODY OIL STRAINER ASSEMBLY

- (a) Install a new O-ring and the oil strainer with the 4 bolts.
Torque: 10 N*m (100 kgf*cm, 7 ft.*lbf)

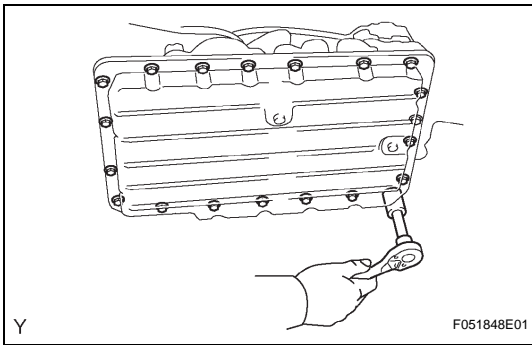

4. INSTALL AUTOMATIC TRANSMISSION OIL PAN SUB-ASSEMBLY

HINT:

Remove the gasket and be careful not to spill oil on the contacting surfaces of the transmission case and oil pan.

(a) Install the oil pan with the 20 bolts.

Torque: 4.4 N*m (45 kgf*cm, 39 in.*lbf)

5. CONNECT CABLE TO NEGATIVE BATTERY TERMINAL

Torque: 3.9 N*m (40 kgf*cm, 35 in.*lbf)

6. PERFORM INITIALIZATION

(See page [AT-19](#))

7. ADJUST AUTOMATIC TRANSMISSION FLUID

(See page [AT-147](#))